

American National Standard

Information technology - ATA/ATAPI-8 Command Set (ATA8-ACS) - Ammendment 1

Approved mm/dd/yyyy:

Secretariat: Information Technology Industry Council

American National Standard

Approval of an American National Standard requires verification by ANSI that the requirements for due process, consensus, and other criteria for approval have been met by the standards developer. Consensus is established when, in the judgment of the ANSI Board of Standards Review, substantial agreement has been reached by directly and materially affected interests. Substantial agreement means much more than a simple majority, but not necessarily unanimity. Consensus requires that all views and objections be considered, and that effort be made towards their resolution.

The use of American National Standards is completely voluntary; their existence does not in any respect preclude anyone, whether he has approved the standards or not, from manufacturing, marketing, purchasing, or using products, processes, or procedures not conforming to the standards.

The American National Standards Institute does not develop standards and will in no circumstances give interpretation on any American National Standard. Moreover, no person shall have the right or authority to issue an interpretation of an American National Standard in the name of the American National Standards Institute. Requests for interpretations should be addressed to the secretariat or sponsor whose name appears on the title page of this standard.

CAUTION NOTICE: This American National Standard may be revised or withdrawn at any time. The procedures of the American National Standards Institute require that action be taken periodically to reaffirm, revise, or withdraw this standard. Purchasers of American National Standards may receive current information on all standards by calling or writing the American National Standards Institute.

Replace a single row in Table 6:**Table 6 — Block Size By Command (part 1 of 2)**

Command	Words Transferred per Block
CFA TRANSLATE SECTOR	256

Insert a single row into Table 9**Table 9 — Security Command Actions (part 3 of 4)**

Command	Locked	Disabled or Unlocked	Frozen
TRUSTED NON-DATA	Command aborted	Executable	Executable

Completely replace section 4.25 with the following text:**4.25 Trusted Computing feature set**

The Trusted Computing feature set provides an interface between a horizontal security product embedded in devices whose behavior may be authorized via interaction with a trusted host system.

The following commands are mandatory for devices implementing the Trusted Computing feature set:

- a) TRUSTED SEND;
- b) TRUSTED SEND DMA;
- c) TRUSTED RECEIVE;
- d) TRUSTED RECEIVE DMA; and
- e) TRUSTED NON-DATA.

TRUSTED SEND and TRUSTED SEND DMA may be used interchangeably. The two commands only differ by the type of data transport protocol used (i.e., PIO Data-Out Command or DMA Command). Similarly, TRUSTED RECEIVE and TRUSTED RECEIVE DMA are interchangeable (i.e., PIO Data-In Command or DMA Command). IDENTIFY DEVICE data word 48 bit 0 indicates whether or not this feature set is supported.

The DEVICE CONFIGURATION OVERLAY SET command provides a mechanism to remove support for this feature set.

The data streams and subsequent actions resulting from these commands are defined by the security protocol identified in the command parameters. These protocols may be defined by groups outside of this standard. The intent is to standardize the data content so it is identical across both ATA and SCSI interfaces.

Completely replace section 4.26 with the following text:**4.26 Write-Read-Verify feature set**

The optional Write-Read-Verify feature set allows a host to control read after write behavior in a device.

To enable or disable the feature of Write-Read-Verify, the host issues a SET FEATURES command with one of the following subcommand codes:

- a) Enable Write-Read-Verify feature set
- b) Disable Write-Read-Verify feature set

It is possible that the device may experience reduced performance when the Write-Read-Verify feature set is enabled.

These commands are affected by this feature:

- c) WRITE DMA
- d) WRITE DMA EXT
- e) WRITE DMA FUA EXT
- f) WRITE DMA QUEUED
- g) WRITE DMA QUEUED EXT
- h) WRITE DMA QUEUED FUA EXT
- i) WRITE FPDMA QUEUED
- j) WRITE MULTIPLE
- k) WRITE MULTIPLE EXT
- l) WRITE MULTIPLE FUA EXT
- m) WRITE SECTOR(S)
- n) WRITE SECTOR(S) EXT

See 7.52.10 for a description of device behavior when this feature set is supported and enabled.

The IDENTIFY DEVICE command shall reflect the supported and enabled or disabled state of this feature set.

When the device's volatile write cache is enabled, the device may report command completion with no error to the host even if the data is in the device volatile write cache and not written and verified to the non-volatile media. This is important to reduce the performance degradation when the Write-Read-Verify feature set is enabled.

If:

- a) the volatile write cache is disabled and any write command is processed by the device;
- b) a forced unit access write command is processed by the device; or
- c) a flush cache command is processed by the device,

then the device shall only report command completion after the data has been verified.

If the Write-Read-Verify feature set is enabled and the device has not already verified the maximum number of logical sectors configured for this feature set, then after after the device has written the sectors to the non-volatile media, the device shall read the data from the non-volatile media and verify that there are no errors. A read from the non-volatile media shall be performed before verification. The verification of sectors is defined as vendor specific.

If the Write-Read-Verify feature set is disabled, or if the device has already verified the maximum number of logical sectors configured for this feature set, then no verification by this feature set shall be performed after the device has written the sectors to the non-volatile media.

If an unrecoverable error condition is encountered by the device during the write, read, or verify operation, the device shall set the Device Fault bit (see 6.2.6) to one.

Completely replace section 4.11.6 with the following text and figures:**4.11.6 HPA State Transition Diagrams****4.11.6.1 State Transition Figures**

The HPA state transition diagrams are in five parts: figure 5, figure 6, figure 7, figure 8 and figure 9.

In the following state transition diagrams, the notation COMMAND (value) refers to the device receiving the command with a specific value or values. For example:

- d) SET MAX ADDRESS (Non-Volatile) means the device successfully processes a SET MAX ADDRESS command with the V_V field set to one; or
- e) SET MAX ADDRESS (Native Max) means the device successfully processes a SET MAX ADDRESS command with the LBA field set to the native max address.

If a state has a transition condition that specifies native max, then any other set max conditions imply a value less than the native max value. If a state has a transition condition that specifies neither volatile nor non-volatile, then both are implied.

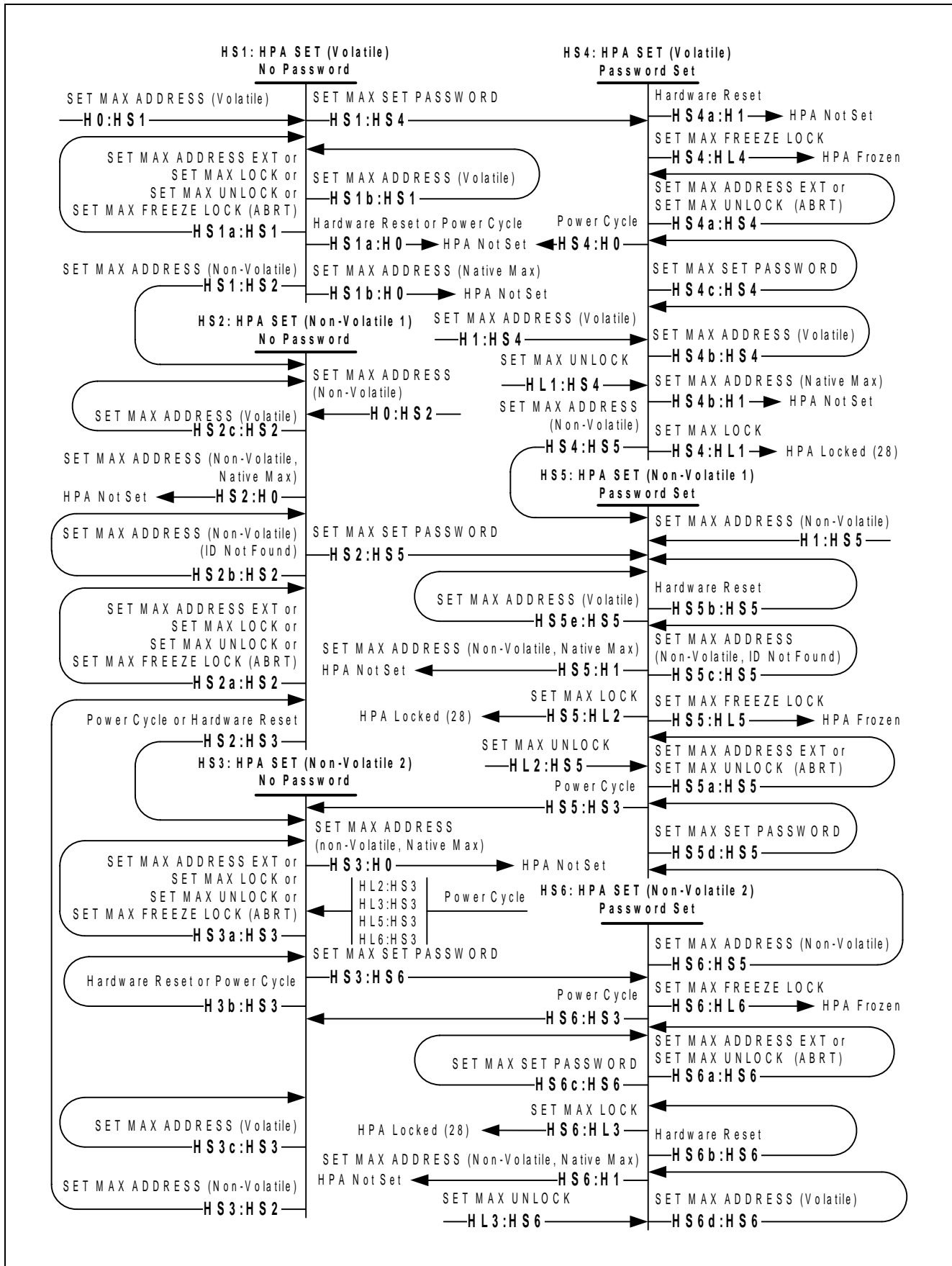

Figure 6 — HPA Set (28)

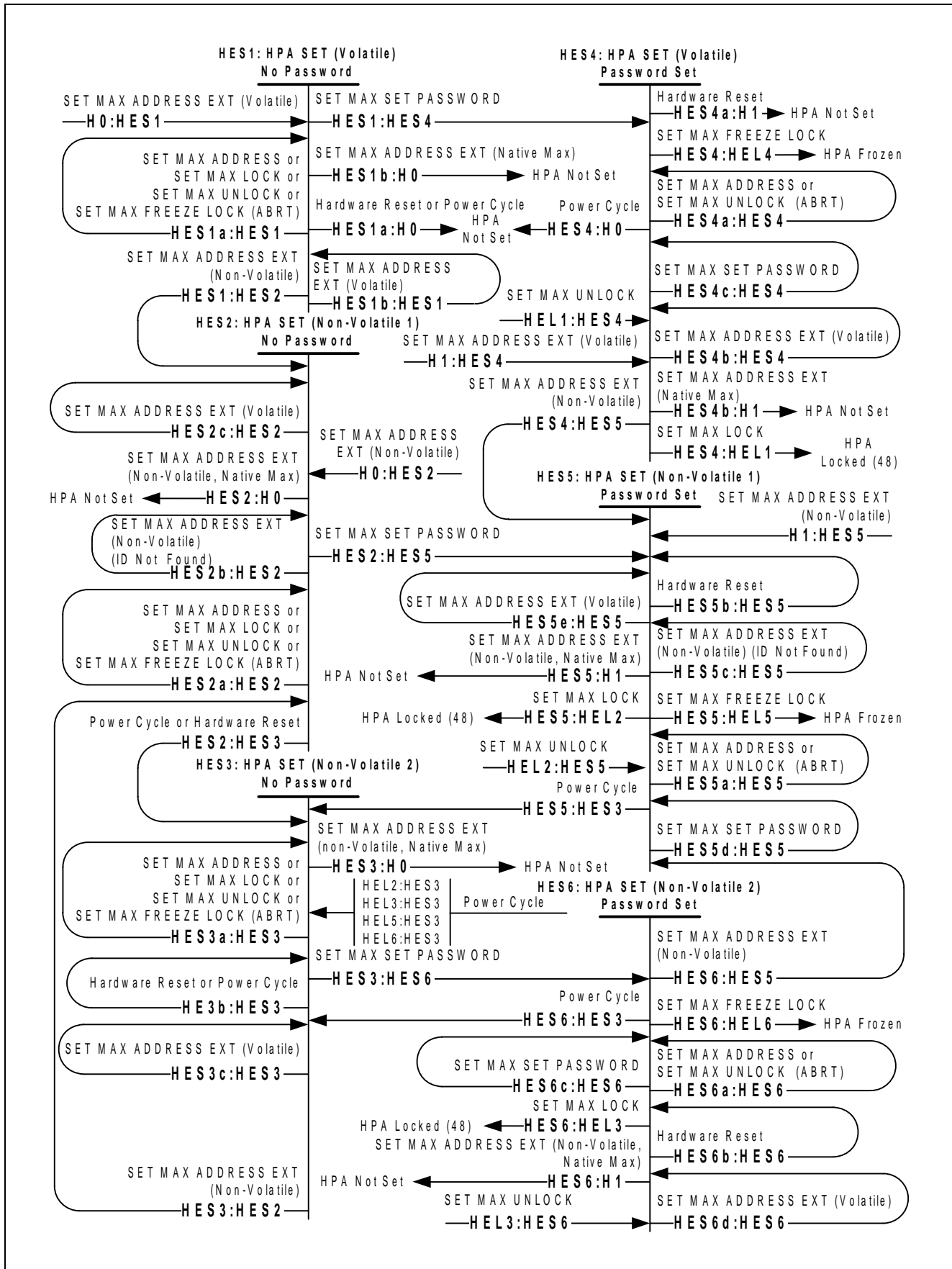

Figure 7 — HPA Set (48)

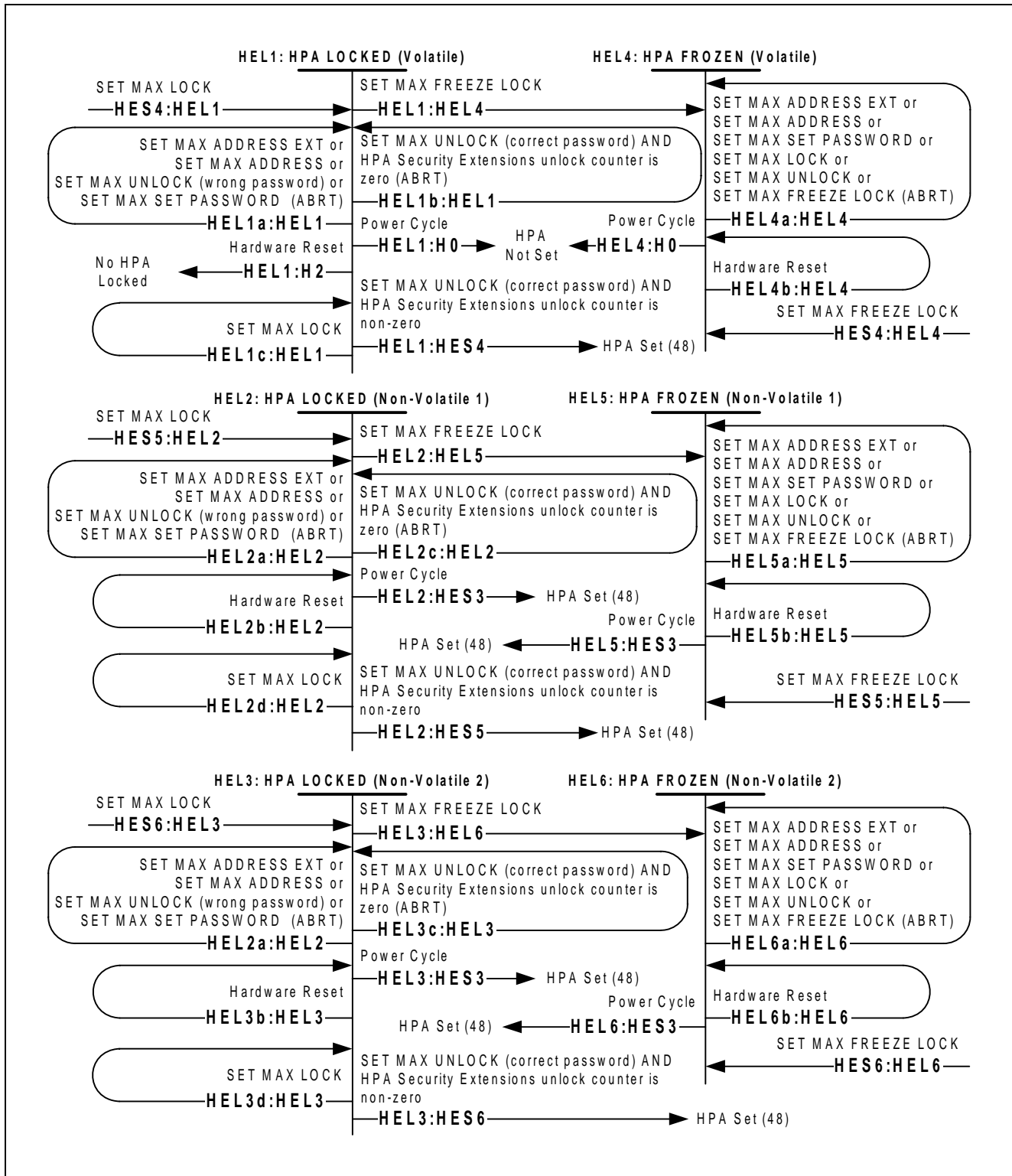

Figure 9 — HPA Locked (48)

4.11.6.2 HPA Not Set

State H0: No HPA/No Password: This state shall be entered when the device is powered on and does not have a non-volatile max address set. In this state the device has not established the HPA and the password has not been set.

Transition H0:H1: When the device successfully processes a SET MAX SET PASSWORD command without error, the device shall transition to the H1 state.

Transition H0:HS1: When the device successfully processes a SET MAX ADDRESS (Volatile) command without error, the device shall process the command and transition to the HS1 state.

Transition H0:HS2: When the device successfully processes a First SET MAX ADDRESS (non-volatile) command without error, the device shall process the command and transition to the HS2 state. A "First SET MAX ADDRESS (non-volatile) command" is the first SET MAX ADDRESS (non-volatile) command processed by the device after a Power-on reset.

Transition H0:HES1: When the device successfully processes a SET MAX ADDRESS EXT (Volatile) command without error, the device shall process the command and transition to the HES1 state.

Transition H0:HES2: When the device successfully processes a SET MAX ADDRESS EXT (Non-Volatile) command without error, the device shall process the command and transition to the HES2 state.

Transition H0a:H0: When the device successfully processes a SET MAX LOCK, SET MAX UNLOCK, SET MAX FREEZE LOCK, additional SET MAX ADDRESS EXT (non-volatile), or an additional SET MAX ADDRESS (non-volatile) command without error, the device shall return command aborted and remain in the same state. An "additional SET MAX ADDRESS (non-volatile) command" is a SET MAX ADDRESS (non-volatile) command that is processed by the device after a previous SET MAX ADDRESS (non-volatile) command has been successfully processed by the device with no intervening Power-on reset.

Transition H0b:H0: When the device successfully processes a SET MAX ADDRESS (Native Max) command or SET MAX ADDRESS EXT (Native Max) command without error, the device shall remain in the same state.

Transition H0c:H0: When the device successfully processes a hardware reset or a power-on reset, the device shall remain in the same state.

State H1: No HPA/Password Set: In this state the device has not established the HPA and the password has been set.

Transition H1:H0: When the device successfully processes a power-on reset, the device shall transition to the H0 state.

Transition H1:H2: When the device successfully processes a SET MAX LOCK command, the device shall transition to the H2 state.

Transition H1:H3: When the device successfully processes a SET MAX FREEZE LOCK command without error, the device shall transition to the H3 state.

Transition H1:HS4: When the device successfully processes a SET MAX ADDRESS (Volatile), the device shall transition to the HS4 state.

Transition H1:HES4: When the device successfully processes a SET MAX ADDRESS EXT (Volatile), the device shall transition to the HES4 state.

Transition H1:HES5: When the device successfully processes a First SET MAX ADDRESS EXT (Non-Volatile), the device shall transition to the HES5 state. A "First SET MAX ADDRESS EXT (non-volatile) command" is the first SET MAX ADDRESS (non-volatile) command processed by the device after a Power-on reset

Transition H1:HS5: When the device successfully processes a First SET MAX ADDRESS (Non-Volatile), the device shall transition to the HS5 state. A "First SET MAX ADDRESS (non-volatile) command" is the first SET MAX ADDRESS (non-volatile) command processed by the device after a Power-on reset.

Transition H1a:H1: When the device successfully processes a SET MAX UNLOCK command, the device shall report command aborted and remain in the same state.

Transition H1b:H1: When the device successfully processes a SET MAX ADDRESS (Native Max) command or a SET MAX ADDRESS EXT (Native Max) command without error, the device shall remain in the same state.

Transition H1c:H1: When the device successfully processes a SET MAX SET PASSWORD command without error, the device shall remain in the same state.

Transition H1d:H1: If the device processes a hardware reset, the device shall remain in the same state.

Transition H1e:H1: When the device successfully processes an additional SET MAX ADDRESS EXT (non-volatile) or an additional SET MAX ADDRESS (non-volatile) command, the device shall return command aborted and remain in the same state. An "additional SET MAX ADDRESS (non-volatile) command" is a SET MAX ADDRESS (non-volatile) command that is processed by the device after a previous SET MAX ADDRESS (non-volatile) command has been successfully processed by the device with no intervening Power-on reset.

State H2: No HPA/Locked: In this state the device is HPA Locked and only the power cycle transits the state to the H0 state.

Transition H2:H0: When the device successfully processes a power-on reset, the device shall transition to the H0 state.

Transition H2:H1: When the device successfully processes a SET MAX UNLOCK command with the correct password, the device shall transition to the H1 state.

Transition H2:H3: When the device successfully processes a SET MAX FREEZE LOCK command with the correct password, the device shall transition to the H3 state.

Transition H2a:H2: When the device successfully processes a SET MAX ADDRESS EXT, SET MAX ADDRESS, or SET MAX SET PASSWORD command, the device shall return command aborted and remain in the same state.

Transition H2b:H2: If the device processes a hardware reset, then the device shall remain in the same state.

Transition H2c:H2: If the device successfully processes a SET MAX LOCK command, the device shall remain in the same state and the device may return command aborted.

State H3: No HPA FROZEN: In this state no HPA is established and the device is locked from all HPA commands. Only a power-cycle shall cause the device to change to another state.

Transition H3:H0: When the device successfully processes a power-on reset, the device shall transition to the H0 state.

Transition H3a:H3: When the device successfully processes a SET MAX ADDRESS EXT, SET MAX ADDRESS, SET MAX LOCK, SET MAX UNLOCK, SET MAX FREEZE LOCK or SET MAX SET PASSWORD command, the device shall return command aborted and remain in the same state.

Transition H3b:H3: When the device processes a hardware reset, the device shall remain in the same state.

4.11.6.3 28-bit HPA Set

State HS1: HPA SET (Volatile)/No Password: In this state the volatile 28-bit HPA is established and the password is not set.

Transition HS1:HS2: When the device successfully processes a SET MAX ADDRESS command without error in non-volatile state, the device shall transition to the HS2 state.

Transition HS1:HS4: When the device successfully processes a SET MAX SET PASSWORD command without error, the device shall transition to the HS4 state.

Transition HS1a:H0: When the device successfully processes a hardware reset or if device processes a power-on reset, the device shall transition to the H0 state.

Transition HS1b:H0: When the device successfully processes a SET MAX ADDRESS (Native Max) command without error, the device shall transition to the H0 state.

Transition HS1a:HS1: When the device successfully processes a SET MAX ADDRESS EXT, SET MAX LOCK, SET MAX UNLOCK or SET MAX FREEZE LOCK command, the device shall return command aborted and remain in the same state.

Transition HS1b:HS1: When the device successfully processes a SET MAX ADDRESS (Volatile) command, the device shall remain in the same state.

State HS2: HPA SET (Non-Volatile 1)/No Password: In this state the non-volatile 28-bit HPA is established and the password is not set.

Transition HS2:H0: When the device successfully processes a SET MAX ADDRESS (Non-Volatile, Native Max) command, the device shall transition to the H0 state.

Transition HS2:HS5: When the device successfully processes a SET MAX SET PASSWORD command, the device shall transition to the HS5 state.

Transition HS2a:HS2: When the device successfully processes a SET MAX ADDRESS EXT, SET MAX LOCK, SET MAX UNLOCK or SET MAX FREEZE LOCK command, the device shall return command aborted and remain in the same state.

Transition HS2b:HS2: When the device successfully processes a SET MAX ADDRESS (Non-Volatile) command, the device shall return ID Not Found and remain in the same state.

Transition HS2c:HS2: When the device successfully processes a SET MAX ADDRESS (Volatile) command, the device shall remain in the same state.

Transition HS2:HS3: When the device successfully processes a power-on reset or a hardware reset, the device shall make transition to the HS3 state.

State HS3: HPA SET (Non-Volatile 2)/No Password: In this state the non-volatile 28-bit HPA is established and the password is not set.

Transition HS3:H0: When the device successfully processes a SET MAX ADDRESS (Non-Volatile, Native Max) command, the device shall transition to the H0 state.

Transition HS3:HS2: When the device successfully processes a SET MAX ADDRESS (Non-Volatile) command without error, the device shall transition to the HS2 state.

Transition HS3:HS6: When the device successfully processes a SET MAX SET PASSWORD command without error, the device shall transition to the HS6 state.

Transition HS3a:HS3: When the device successfully processes a SET MAX ADDRESS EXT, SET MAX LOCK, SET MAX UNLOCK or SET MAX FREEZE LOCK command, the device shall return command aborted and remain in the same state.

Transition HS3b:HS3: When the device successfully processes a hardware reset or when the device successfully processes a power-on reset, the device shall remain in the same state.

Transition HS3c:HS3: When the device successfully processes a SET MAX ADDRESS (Volatile) command without error, the device shall remain in the same state.

State HS4: HPA SET (Volatile)/Password Set: In this state the volatile 28-bit HPA is established and the password is set.

Transition HS4:HL1: When the device successfully processes a SET MAX LOCK command, the device shall transition to the HL1 state.

Transition HS4:HL4: When the device successfully processes a SET MAX FREEZE LOCK command, the device shall transition to the HL4 state.

Transition HS4:H0: When the device successfully processes a power-on reset, the device shall transition to the H0 state.

Transition HS4:HS5: When the device successfully processes a SET MAX ADDRESS (Non-Volatile) command, the device shall process the command and transition to the HS5 state.

Transition HS4a:H1: When the device processes a hardware reset, the device shall transition to the H1 state.

Transition HS4b:H1: When the device successfully processes a SET MAX ADDRESS (Native Max) command without error, the device shall transition to the H1 state.

Transition HS4a:HS4: When the device successfully processes a SET MAX ADDRESS EXT or SET MAX UNLOCK command, the device shall return command aborted and remain in the same state.

Transition HS4b:HS4: When the device successfully processes a SET MAX ADDRESS (Volatile), the device shall remain in the same state.

Transition HS4c:HS4: When the device successfully processes a SET MAX SET PASSWORD command, the device shall remain in the same state.

State HS5: HPA SET (Non-Volatile 1)/Password Set: In this state the non-volatile 28-bit HPA is established and the password is set.

Transition H1:HS5: When the device successfully processes a SET MAX ADDRESS (Non-Volatile), the device shall transition to the HS5 state.

Transition HS5:H1: When the device successfully processes a SET MAX ADDRESS (Native Max) command, the device shall transition to the H1 state.

Transition HS5:HL2: When the device successfully processes a SET MAX LOCK command, the device shall transition to the HL2 state.

Transition HS5:HL5: When the device successfully processes a SET MAX FREEZE LOCK command, the device shall transition to the HL5 state.

Transition HS5:HS3: When the device successfully processes a power-on reset, the device shall transition to the HS3 state.

Transition HS5a:HS5: When the device successfully processes a SET MAX ADDRESS EXT or SET MAX UNLOCK command, the device shall return command aborted and remain in the same state.

Transition HS5b:HS5: When the device successfully processes a hardware reset, the device shall remain in the same state.

Transition HS5c:HS5: When the device successfully processes a SET MAX ADDRESS (Non-Volatile), the device shall return ID Not Found and remain in the same state.

Transition HS5d:HS5: When the device successfully processes a SET MAX SET PASSWORD command, the device shall remain in the same state.

Transition HS5e:HS5: When the device successfully processes a SET MAX ADDRESS (Volatile) command, the device shall remain in the same state.

State HS6: HPA SET (Non-Volatile 2)/Password Set: In this state the non-volatile 28-bit HPA is established and the password is set.

Transition HS6:HS5: When the device successfully processes a SET MAX ADDRESS (Non-Volatile), the device shall transition to the HS5 state.

Transition HS6:H1: When the device successfully processes a SET MAX ADDRESS (Non-Volatile, Native Max) command, the device shall transition to the H1 state.

Transition HS6:HL3: When the device successfully processes a SET MAX LOCK command, the device shall transition to the HL3 state.

Transition HS6:HL6: When the device successfully processes a SET MAX FREEZE LOCK command, the device shall transition to the HL6 state.

Transition HS6:HS3: When the device successfully processes a power-on reset, the device shall transition to the HS3 state.

Transition HS6a:HS6: When the device successfully processes a SET MAX ADDRESS EXT or SET MAX UNLOCK command, the device shall return command aborted and remain in the same state.

Transition HS6b:HS6: When the device successfully processes a hardware reset, the device shall remain in the same state.

Transition HS6c:HS6: When the device successfully processes a SET MAX SET PASSWORD command, the device shall remain in the same state.

Transition HS6d:HS6: When the device successfully processes a SET MAX ADDRESS (Volatile) command, the device shall remain in the same state.

4.11.6.4 48-Bit HPA Set

State HES1: HPA SET (Volatile)/No Password: In this state the volatile 48-bit HPA is established and the password is not set.

Transition HES1:HES2: When the device successfully processes a SET MAX ADDRESS EXT (Non-Volatile), the device shall transition to the HES2 state.

Transition HES1:HES4: When the device successfully processes a SET MAX SET PASSWORD command, the device shall transition to the HES4 state.

Transition HES1a:H0: When the device successfully processes a hardware reset or if the device successfully processes a power-on reset, the device shall transition to the H0 state.

Transition HES1b:H0: When the device successfully processes a SET MAX ADDRESS (Native Max) command, the device shall transition to the H0 state.

Transition HES1a:HES1: When the device successfully processes a SET MAX ADDRESS, SET MAX LOCK, SET MAX UNLOCK or SET MAX FREEZE LOCK command, the device shall return command aborted and remain in the same state.

Transition HES1b:HES1: When the device successfully processes a SET MAX ADDRESS EXT (Volatile) command, the device shall remain in the same state.

State HES2: HPA SET (Non-Volatile 1)/No Password: In this state the non-volatile 48-bit HPA is established and the password is not set.

Transition HES2:H0: When the device successfully processes a SET MAX ADDRESS EXT (Non-Volatile, Native Max) command, the device shall transition to the H0 state.

Transition HES2:HES3: When the device successfully processes a power-on reset or a hardware reset, the device shall transition to the HES3 state.

Transition HES2:HES5: When the device successfully processes a SET MAX SET PASSWORD command, the device shall transition to the HES5 state.

Transition HES2a:HES2: When the device successfully processes a SET MAX ADDRESS, SET MAX LOCK, SET MAX UNLOCK or SET MAX FREEZE LOCK command, the device shall return command aborted and remain in the same state.

Transition HES2b:HES2: When the device successfully processes a SET MAX ADDRESS EXT (Non-Volatile), the device shall return ID Not Found and remain in the same state.

Transition HES2c:HES2: When the device successfully processes a SET MAX ADDRESS EXT (Volatile) command, the device shall remain in the same state.

State HES3: HPA SET (Non-Volatile 2)/No Password: In this state the non-volatile 48-bit HPA is established and the password is not set.

Transition HES3:H0: When the device successfully processes a SET MAX ADDRESS EXT (Non-Volatile, Native Max) command, the device shall transition to the H0 state.

Transition HES3:HES2: When the device successfully processes a SET MAX ADDRESS EXT (Non-Volatile) command, the device shall transition to the HES2 state.

Transition HES3:HES6: When the device successfully processes a SET MAX SET PASSWORD command, the device shall transition to the HES6 state.

Transition HES3a:HES3: When the device successfully processes a SET MAX ADDRESS EXT, SET MAX LOCK, SET MAX UNLOCK or SET MAX FREEZE LOCK command, the device shall return command aborted and remain in the same state.

Transition HES3b:HES3: When the device successfully processes a hardware reset or when the device successfully processes a power-on reset, the device shall remain in the same state.

Transition HES3c:HES3: When the device processes a SET MAX ADDRESS EXT (Volatile) command without error, the device shall remain in the same state..

State HES4: HPA SET (Volatile)/Password Set: In this state the volatile 48-bit HPA is established and the password is set.

Transition HES4:H0: When the device successfully processes a power-on reset, the device shall transition to the H0 state.

Transition HES4:HES5: When the device successfully processes a SET MAX ADDRESS EXT (Non-Volatile) command, the device shall transition to the HES5 state.

Transition HES4:HEL1: When the device successfully processes a SET MAX LOCK command, the device shall transition to the HEL1 state.

Transition HES4a:H1: When the device processes a hardware reset, the device shall transition to the H1 state.

Transition HES4b:H1: When the device successfully processes a SET MAX ADDRESS (Native Max) command, the device shall transition to the H1 state.

Transition HES4:HEL4: When the device successfully processes a SET MAX FREEZE LOCK command, the device shall transition to the HEL4 state.

Transition HES4a:HES4: When the device successfully processes a SET MAX ADDRESS or SET MAX UNLOCK command, the device shall return command aborted and remain in the same state.

Transition HES4b:HES4: When the device successfully processes a SET MAX ADDRESS EXT (Volatile) command, the device shall remain in the same state.

Transition HES4c:HES4: When the device successfully processes a SET MAX SET PASSWORD command, the device shall remain in the same state.

State HES5: HPA SET (Non-Volatile 1)/Password Set: In this state the non-volatile 48-bit HPA is established and the password is set.

Transition HES5:H1: When the device successfully processes a SET MAX ADDRESS EXT (Non-volatile, Native Max) command, the device shall transition to the H1 state.

Transition HES5:HEL2: When the device successfully processes a SET MAX LOCK command, the device shall transition to the HEL2 state.

Transition HES5:HES3: When the device successfully processes a power-on reset, the device shall transition to the HES3 state.

Transition HES5:HEL5: When the device successfully processes a SET MAX FREEZE LOCK command, the device shall transition to the HEL5 state.

Transition HES5a:HES5: When the device successfully processes a SET MAX ADDRESS or SET MAX UNLOCK command, the device shall return command aborted and remain in the same state.

Transition HES5b:HES5: When the device successfully processes a hardware reset, the device shall remain in the same state.

Transition HES5c:HES5: When the device successfully processes a SET MAX ADDRESS EXT (Non-Volatile) command, the device shall return command aborted and remain in the same state.

Transition HES5d:HES5: When the device successfully processes a SET MAX SET PASSWORD command, the device shall remain in the same state.

Transition HES5e:HES5: When the device successfully processes a SET MAX ADDRESS EXT (Volatile) command, the device shall remain in the same state.

State HES6: HPA SET (Non-Volatile 2)/Password Set: In this state the non-volatile 48-bit HPA is established and the password is set.

Transition HES6:HES5: When the device successfully processes a SET MAX ADDRESS EXT (Non-Volatile) command, the device shall transition to the HES5 state.

Transition HES6:H1: When the device successfully processes a SET MAX ADDRESS EXT (Non-Volatile, Native Max) command, the device shall transition to the H1 state.

Transition HES6:HEL3: When the device successfully processes a SET MAX LOCK command, the device shall transition to the HEL3 state.

Transition HES6:HES3: When the device successfully processes a power-on reset, the device shall transition to the HES3 state.

Transition HES6:HEL6: When the device successfully processes a SET MAX FREEZE LOCK command, the device shall transition to the HEL6 state.

Transition HES6a:HES6: When the device successfully processes a SET MAX ADDRESS or SET MAX UNLOCK command, the device shall return command aborted and remain in the same state.

Transition HES6b:HES6: When the device successfully processes a hardware reset, the device shall remain in the same state.

Transition HES6c:HES6: When the device successfully processes a SET MAX SET PASSWORD command, the device shall remain in the same state.

Transition HES6d:HES6: When the device successfully processes a SET MAX ADDRESS EXT (Volatile) command, the device shall remain in the same state.

4.11.6.5 28-Bit HPA Locked

State HL1: HPA LOCKED (Volatile): In this state the volatile 28-bit HPA is established, and the device is locked from HPA commands, except the SET MAX UNLOCK command, with a proper password or the SET MAX FREEZE LOCK command.

Transition HL1:H0: When the device successfully processes a power-on reset, the device shall transition to the H0 state.

Transition HL1:HL4: When the device successfully processes a SET MAX FREEZE LOCK command, the device shall transition to the HL4 state.

Transition HL1:HS4: When the device successfully processes a SET MAX UNLOCK (correct password) command, and the HPA Security Extensions unlock counter is non-zero, the device shall transition to the HS4 state.

Transition HL1:H2: When the device successfully processes a hardware reset, the device shall transition to the H2 state.

Transition HL1a:HL1: When the device successfully processes a SET MAX ADDRESS EXT, SET MAX ADDRESS, SET MAX UNLOCK (wrong password) or SET MAX SET PASSWORD command, the device shall return command aborted and remain in the same state.

Transition HL1b:HL1: When the device successfully processes a SET MAX UNLOCK (correct password) and the HPA Security Extensions unlock counter is zero, the device shall return command aborted and remain in the same state.

Transition HL1c:HL1: If the device successfully processes a SET MAX LOCK command, the device shall remain in the same state and the device may return command aborted.

State HL2: HPA LOCKED (Non-volatile 1): In this state the non-volatile 28-bit HPA is established, and the device is locked from HPA commands except the SET MAX UNLOCK command with a proper password or the SET MAX FREEZE LOCK command.

Transition HL2:HL5: When the device successfully processes a SET MAX FREEZE LOCK command, the device shall transition to the HL5 state.

Transition HL2:HS3: When the device successfully processes a power-on reset, the device shall transition to the HS3 state.

Transition HL2:HS5: When the device successfully processes a SET MAX UNLOCK (correct password) command and the HPA Security Extensions unlock counter is non-zero, the device shall transition to the HS5 state.

Transition HL2a:HL2: When the device successfully processes a SET MAX ADDRESS EXT, SET MAX ADDRESS, SET MAX UNLOCK (wrong password) or SET MAX SET PASSWORD command, the device shall return command aborted and remain in the same state.

Transition HL2b:HL2: When the device successfully processes a hardware reset, the device shall remain in the same state.

Transition HL2c:HL2: When the device successfully processes a SET MAX UNLOCK (correct password) command and the HPA Security Extensions unlock counter is zero, the device shall shall return command aborted and remain in the same state..

Transition HL2d:HL2: If the device successfully processes a SET MAX LOCK command, the device shall remain in the same state and the device may return command aborted.

State HL3: HPA LOCKED (Non-volatile 2): In this state a non-volatile 28-bit HPA is established, and the device is locked from HPA commands except the SET MAX UNLOCK command with a proper password or the SET MAX FREEZE LOCK command.

Transition HL3:HL6: When the device successfully processes a SET MAX FREEZE LOCK command, the device shall transition to the HL6 state.

Transition HL3:HS3: When the device successfully processes a power-on reset, the device shall transition to the HS3 state.

Transition HL3:HS6: When the device successfully processes a SET MAX UNLOCK command without error with the correct password and the HPA Security Extensions unlock counter is non-zero, the device shall transition to the HS6 state.

Transition HL3a:HL3: When the device successfully processes a SET MAX ADDRESS EXT, SET MAX ADDRESS, SET MAX UNLOCK (wrong password) or SET MAX SET PASSWORD command, the device shall return command aborted and remain in the same state. If a SET MAX UNLOCK (wrong password) is successfully processes the HPA Security Extensions unlock counter shall be decremented by 1.

Transition HL3b:HL3: When the device successfully processes a hardware reset, the device shall remain in the same state.

Transition HL3c:HL3: When the device successfully processes a SET MAX UNLOCK (correct password) command and the HPA Security Extensions unlock counter is zero, the device shall return command aborted and remain in the same state.

Transition HL3d:HL3: If the device successfully processes a SET MAX LOCK command, the device shall remain in the same state and the device may return command aborted.

State HL4: HPA FROZEN (Volatile): In this state a volatile 28-bit HPA is established and the device is locked from all HPA commands.

Transition HL4:H0: When the device successfully processes a power-on reset, the device shall transition to the H0 state.

Transition HL4a:HL4: When the device successfully processes a SET MAX ADDRESS EXT, SET MAX ADDRESS, SET MAX LOCK, SET MAX UNLOCK, SET MAX FREEZE LOCK or SET MAX SET PASSWORD command, the device shall return command aborted and remain in the same state.

Transition HL4b:HL4: When the device processes a hardware reset, the device shall remain in the same state.

State HL5: HPA FROZEN (Non-Volatile 1): In this state the non-volatile 28-bit HPA is established and the device is locked from all HPA commands.

Transition HL5a:HL5: When the device successfully processes a SET MAX ADDRESS EXT, SET MAX ADDRESS, SET MAX LOCK, SET MAX UNLOCK, SET MAX FREEZE LOCK or SET MAX SET PASSWORD command, the device shall return command aborted and remain in the same state.

Transition HL5b:HL5: When the device successfully processes a hardware reset, the device shall remain in the same state.

Transition HL5:HS3: When the device successfully processes a power-on reset, the device shall transition to the HS3 state.

State HL6: HPA FROZEN (Non-Volatile 2): In this state the non-volatile 28-bit HPA is established and the device is locked from all HPA commands.

Transition HL6:HS3: When the device successfully processes a power-on reset, the device shall transition to the HS3 state.

Transition HL6a:HL6: When the device successfully processes a SET MAX ADDRESS EXT, SET MAX ADDRESS, SET MAX LOCK, SET MAX UNLOCK, SET MAX FREEZE LOCK or SET MAX SET PASSWORD command, the device shall return command aborted and remain in the same state.

Transition HL6b:HL6: When the device successfully processes a hardware reset, the device shall remain in the same state.

4.11.6.6 48-Bit HPA Locked

State HEL1: HPA LOCKED (Volatile): In this state a volatile 48-bit HPA is established, and the device is locked from HPA commands, except the SET MAX UNLOCK command, with a proper password or the SET MAX FREEZE LOCK command.

Transition HEL1:H0: When the device processes a power-on reset, the device shall transition to the H0 state.

Transition HEL1:H2: When the device successfully processes a hardware reset, the device shall transition to the H2 state.

Transition HEL1:HEL4: When the device successfully processes a SET MAX FREEZE LOCK command, the device shall transition to the HEL4 state.

Transition HEL1:HES4: When the device successfully processes a SET MAX UNLOCK (correct password) command and the HPA Security Extensions unlock counter is non-zero; the device shall transition to the HES4 state.

Transition HEL1a:HEL1: When the device successfully processes a SET MAX ADDRESS, SET MAX ADDRESS EXT, SET MAX UNLOCK (wrong password) or SET MAX SET PASSWORD command, the device shall return command aborted and remain in the same state.

Transition HEL1b:HEL1: When the device successfully processes a SET MAX UNLOCK (correct password) and the HPA Security Extensions unlock counter is zero, the device shall return command aborted and remain in the same state.

Transition HEL1c:HEL1: If the device successfully processes a SET MAX LOCK command, the device shall remain in the same state and the device may return command aborted.

State HEL2: HPA LOCKED (Non-volatile 1): In this state a non-volatile 48-bit HPA is established, and the device is locked from HPA commands, except the SET MAX UNLOCK command, with a proper password or the SET MAX FREEZE LOCK command.

Transition HES5:HEL2: When the device successfully processes a SET MAX LOCK command, the device shall transition to the HEL2 state.

Transition HEL2:HEL5: When the device successfully processes a SET MAX FREEZE LOCK command, the device shall transition to the HEL5 state.

Transition HEL2:HES3: When the device successfully processes a power-on reset, the device shall transition to the HES3 state.

Transition HEL2:HES5: When the device successfully processes a SET MAX UNLOCK (correct password) command and the HPA Security Extensions unlock counter is non-zero, the device shall transition to the HES5 state.

Transition HEL2a:HEL2: When the device successfully processes a SET MAX ADDRESS, SET MAX ADDRESS EXT, SET MAX UNLOCK (wrong password) or SET MAX SET PASSWORD command, the device shall return command aborted and remain in the same state.

Transition HEL2b:HEL2: When the device successfully processes a hardware reset, the device shall transition to the HEL2 state.

Transition HEL2c:HEL2: When the device successfully processes a SET MAX UNLOCK (correct password) command and the HPA Security Extensions unlock counter is zero, the device shall return command aborted and remain in the same state.

Transition HEL2d:HEL2: If the device successfully processes a SET MAX LOCK command, the device shall remain in the same state and the device may return command aborted.

State HEL3: HPA LOCKED (Non-volatile 2): In this state a non-volatile 48-bit HPA is established, and the device is locked from HPA commands, except the SET MAX UNLOCK command, with a proper password or the SET MAX FREEZE LOCK command.

Transition HEL3:HEL6: When the device successfully processes a SET MAX FREEZE LOCK command, the device shall transition to the HEL6 state.

Transition HEL3:HES3: When the device successfully processes a power-on reset, the device shall transition to the HES3 state.

Transition HEL3:HES6: When the device successfully processes a SET MAX UNLOCK command with the correct password and the HPA Security Extensions unlock counter is non-zero, the device shall transition to the HES6 state.

Transition HEL3a:HEL3: When the device successfully processes a SET MAX ADDRESS, SET MAX ADDRESS EXT, SET MAX UNLOCK (wrong password) or SET MAX SET PASSWORD command, the device shall return command aborted and remain in the same state. If a SET MAX UNLOCK (wrong password) is received the HPA Security Extensions unlock counter shall be decremented by 1.

Transition HEL3b:HEL3: When the device successfully processes a Hardware reset, the device shall remain in the same state.

Transition HEL3c:HEL3: When the device successfully processes a SET MAX UNLOCK (correct password) command and the HPA Security Extensions unlock counter is zero, the device shall return command aborted and remain in the same state.

Transition HEL3d:HEL3: If the device successfully processes a SET MAX LOCK command, the device shall remain in the same state and the device may return command aborted.

State HEL4: HPA FROZEN (Volatile): In this state the volatile 48-bit HPA is established and the device is locked from all HPA commands.

Transition HEL4:H0: When the device successfully processes a power-on reset, the device shall transition to the H0 state.

Transition HEL4a:HEL4: When the device successfully processes a SET MAX ADDRESS, SET MAX ADDRESS EXT, SET MAX LOCK, SET MAX UNLOCK, SET MAX FREEZE LOCK or SET MAX SET PASSWORD command, the device shall return command aborted and remain in the same state.

Transition HEL4b:HEL4: When the device successfully processes a hardware reset, the device shall remain in the same state.

HEL5: HPA FROZEN (Non-Volatile 1): In this state the non-volatile 48-bit HPA is established, and the device is locked from all HPA commands.

Transition HEL5a:HEL5: When the device successfully processes a SET MAX ADDRESS, SET MAX ADDRESS EXT, SET MAX LOCK, SET MAX UNLOCK, SET MAX FREEZE LOCK or SET MAX SET PASSWORD command, the device shall return command aborted and remain in the same state.

Transition HEL5b:HEL5: When the device successfully processes a hardware reset, the device shall remain in the same state.

Transition HEL5:HES3: When the device successfully processes a power-on reset, the device shall transition to the HES3 state.

State HEL6: HPA FROZEN (Non-Volatile 2): In this state a non-volatile 48-bit HPA is established, and the device is locked from all HPA commands.

Transition HEL6:HES3: When the device successfully processes a power-on reset, the device shall transition to the HES3 state.

Transition HEL6a:HEL6: When the device successfully processes a SET MAX ADDRESS, SET MAX ADDRESS EXT, SET MAX LOCK, SET MAX UNLOCK, SET MAX FREEZE LOCK or SET MAX SET PASSWORD command, the device shall return command aborted and remain in the same state.

Transition HEL6b:HEL6: When the device successfully processes a hardware reset, the device shall remain in the same state.

Completely replace section 7.48.10 with the following text:**7.48.10 Enable/Disable Write-Read-Verify feature set**

Subcommand code 0Bh enables the Write-Read-Verify feature set.

Bits (7:0) of the LBA field in the SET FEATURES command specify the Write-Read-Verify mode. Table 1 defines the Write-Read-Verify modes.

Table 1 — Write-Read-Verify Modes

Mode	Description
00h ^a	Always enabled (i.e., the device shall perform a Write-Read-Verify for all logical sectors for all write commands).
01h ^a	The device shall perform a Write-Read-Verify on the first 65,536 logical sectors written by the host after: <ol style="list-style-type: none"> a) spin-up; or b) the device completes a SET FEATURES command setting the Write-Read-Verify mode without error.
02h ^a	The number of logical sectors on which a device performs a Write-Read-Verify is vendor specific.
03h	The device shall perform a Write-Read-Verify on the first (number specified by the Count field in the SET FEATURES command x 1,024) logical sectors written by the host after: <ol style="list-style-type: none"> a) spin-up; or b) the device completes a SET FEATURES command setting the Write-Read-Verify mode without error.
04h-FFh	Reserved
^a the Count field shall be ignored.	

Subcommand code 8Bh disables the Write-Read-Verify feature set.

A device shall set the Write-Read-Verify feature set to its factory default setting after processing of a power-on reset or if the Software Settings Preservation feature set is disabled and a hardware reset is processed. If the Software Settings Preservation feature set is enabled and a hardware reset is processed, the device shall not change the settings of the Write-Read-Verify feature set.

If a device is in the reverting to defaults enabled mode (see 7.48.16), then the device shall set the Write-Read-Verify feature set to its factory default setting after processing of a software reset.

If a device is in the reverting to defaults disabled mode (see 7.48.16), then the device shall not change the settings of the Write-Read-Verify feature set after processing of a software reset.

Completely replace section 7.49.6 with the following text:

7.49.6 SET MAX UNLOCK - F9h/03h, PIO Data-Out

7.49.6.1 Feature Set

This 28-bit command is mandatory for devices that implement the HPA Security Extensions.

7.49.6.2 Description

This command requests a transfer of a single 512-byte block of data from the host. Table 59 defines the content of this data.

The password supplied in the data transferred shall be compared with the password set by the SET MAX SET PASSWORD command.

If the device is locked from HPA commands and the password compare fails, then the device shall return command aborted and decrement the HPA Security Extensions unlock counter. This counter shall be decremented for each password mismatch when SET MAX UNLOCK is issued and the device is locked from HPA commands. When this counter reaches zero in a device, then the device shall return command aborted for all subsequent SET MAX UNLOCK commands until after the device has processed a power-on reset.

NOTE 1 — The HPA Security Extensions unlock counter is not related to the Security feature set unlock counter.

If the device is HPA Locked, the HPA Security Extensions unlock counter is not zero, and the password compare matches, then the device is HPA Unlocked and all SET MAX commands shall be accepted.

This command should not be immediately preceded by a READ NATIVE MAX ADDRESS command. If this command is immediately preceded by a READ NATIVE MAX ADDRESS command, it shall be interpreted as a SET MAX ADDRESS command.

7.49.6.3 Inputs

Name	Description
Feature	03h
Count	N/A
LBA	N/A
Device	<p style="text-align: center;">Bit Description</p> <p style="text-align: center;">7 Obsolete</p> <p style="text-align: center;">6 N/A</p> <p style="text-align: center;">5 Obsolete</p> <p style="text-align: center;">4 Transport Dependent - See 6.2.11</p> <p style="text-align: center;">3:0 Reserved</p>
Command	7:0 F9h

7.49.6.4 Normal Outputs

See table 99.

7.49.6.5 Error Outputs

If a device is not HPA Locked, then the device shall return command aborted. A device may return command completion with the Error bit set to one if an Interface CRC error has occurred. See table 126.

7.49.6.6 Output From the Host to the Device Data Structure

See Table 59

0.1 TRUSTED NON-DATA - 5Bh, Non-Data

0.1.1 Feature Set

This 28-bit command is mandatory for devices implementing the Trusted Computing feature set.

0.1.2 Description

The TRUSTED NON-DATA command delivers the SP Specific field using the specified Security Protocol.

0.1.3 Inputs

0.1.3.1 Overview

Name	Description
Feature	Security Protocol (see 7.57.3.2)
Count	Reserved
LBA	<p>Bit Description</p> <p>27:25 Reserved</p> <p>24 0 - Non-Data TRUSTED SEND, 1 - Non-Data TRUSTED RECEIVE</p> <p>23:8 SP Specific - Security Protocol Specific (see 7.57.6)</p> <p>7:0 Reserved</p>
Device	<p>Bit Description</p> <p>7 Obsolete</p> <p>6 N/A</p> <p>5 Obsolete</p> <p>4 Transport Dependent (See 6.2.11)</p> <p>3:0 Reserved</p>
Command	7:0 5Bh

0.1.3.2 Security Protocol

If Bit 24 is cleared to zero then see 7.59.3.2; otherwise, see 7.57.3.2.

0.1.4 Normal Outputs

If Bit 24 is cleared to zero then see 7.59.4; otherwise, see 7.57.4.

0.1.5 Error Outputs

If Bit 24 is cleared to zero then see 7.59.5; otherwise, see 7.57.5.