

X3T13/96104r1

Formerly X3T10/95-258

4 December 1995

ATA Overlap Proposal

Point of contact:

Pete McLean
Maxtor Corporation
2190 Miller Drive
Longmont, CO 80501-6744
USA

Tel: 303-678-2149
Fax: 303-682-4811
Email: pete_mclean@maxtor.com

Scope

This document presents the detailed text changes to the ATA-3 document (X3T10/2008Dr6) for the Overlap proposal. It is based on the Overlap proposal submitted by Western Digital Corporation (X3T10/95-258r0) with the changes presented by Quantum Corporation (X3T10/95-257r0).

The text to be added to Clause 7 is presented first to provide an introduction to overlap and command queuing. The remainder of the document presents material in the order that it will appear in the ATA document.

Revision History

Revision 1 - Draft created from WD proposal X3T10/95-258r1

Revision 2 - Protocol diagram added

Revision 3 - Added timing diagram. Made revisions requested at page by page review at 24 August 1995 meeting.

Revision 4 - Removed PIO commands, added state diagram and timing diagrams. Major editorial changes.

Revision D96104r1 - Added selected as a state bit in state and timing diagrams.

7.* Command overlap and command queuing feature set

Command overlap is an optional feature that allows a host to issue commands or service outstanding commands with one device while a command is outstanding to the second device. For example, the host may issue a command to the first device and before the command is completed (i.e., requested data is transferred) , select the second device and issue the second device a command.

Command queuing is an optional feature that allows a host to have multiple commands outstanding to a given device. That is, before a first command has completed (i.e., requested data is transferred) additional commands may be issued to the device. A device that supports command queuing shall also support command overlap.

7.*.1 Command Overlap

Command overlap is accomplished by the use of the following mechanisms.

1. Information in the IDENTIFY DEVICE command response that notifies the host that the device supports the command overlap feature.
2. The SET FEATURES command that allows the host to enable the command overlap feature.
3. An overlap command set that identifies those commands that may be overlapped.
4. A mechanism called Release that allows the host to select the second device when the first device has an overlapped command outstanding.
5. A Proxy Interrupt mechanism that allows an unselected device to signal the host that it wishes to continue execution of an outstanding overlapped command.
6. A SERVICE command that allows the host to reselect a device that has an overlapped command outstanding so that command execution may be continued.

7.*.1.1 Overlap IDENTIFY DEVICE information

Bits in word 82 in the IDENTIFY DEVICE response informs the host if the device supports Command Overlap and Command Queuing. Word 71 informs the host of the maximum time from the issuing of an overlap command to the negation of BSY during the Release process. Word 72 informs the host of the maximum time from the issuing of a SERVICE command to the negation of BSY during the Release process. See Clause *.* , IDENTIFY DEVICE.

7.*.1.2 Overlap SET FEATURES command

The issuing of a SET FEATURES command with the Features register content 5Fh or DFh, enables or disables the use of the Proxy interrupt mechanism and is mandatory for the use of the Overlap feature.

The issuing of a SET FEATURES command with the Features register content 5Dh or DDh, enables or disables the issuing of an interrupt when the Release process has completed (i.e., BSY negated) after the issuing of an overlapped command. This allows a host to determine whether it needs to or wishes to poll the BSY bit or whether it prefers an interrupt.

The issuing of a SET FEATURES command with the Features register content 5Eh or DEh, enables or disables the issuing of an interrupt when the Release process has completed (i.e.,

BSY negated) after the issuing of a SERVICE command. This allows a host to determine whether it needs to or wishes to poll the BSY bit or whether it prefers an interrupt when the BSY bit is negated.

See Clause ***.***, SET FEATURES.

7.*.1.3 Overlap commands

The only commands that shall be overlapped are PACKET (see X3T10/1120D ATAPI), READ DMA OVERLAP, and WRITE DMA OVERLAP. All other commands shall complete execution before both BSY and DRQ are negated. These three overlap commands shall be issued only when the Enable Proxy Interrupt SET FEATURE command has been executed.

The device shall execute the Release mechanism and issue Proxy interrupts only when one of these three commands is outstanding (i.e., from the issuing of the command to the Status register read at the completion of the command). The host shall only issue the SERVICE command when one of these three commands is outstanding to the device. The contents of the Features, Sector Count, Alternate Status, and Status registers are redefined for the issuing of these commands and remain redefined until the completion of these commands. See ***.***, ***.***, and ***.***.

If an overlap command is issued while a none overlap command is in progress, both the command is progress and the newly issued command shall be aborted. The ending status shall be ABORT command and the results are indeterminant.

7.*.1.4 Release

Upon the receipt of an overlapped command, the device shall “save” the command and its required parameters.

If the release interrupt has been enabled via the SET FEATURES command, the device shall release by setting REL , clearing BSY and asserting INTRQ regardless of whether the data is ready to transfer or not.

If the release interrupt has not been enabled via the SET FEATURES command, the device may either release or transfer data immediately if the data is available. To release, the device sets REL and clears BSY, freeing the bus for the selection of the other device. To transfer the data immediately, the device sets DRQ and DMARQ, clears BSY and waits for the host to transfer the data.

Once the REL bit has been set indicating that the device has released an overlap command in progress, the REL bit shall remain set until that overlap command has completed, i.e., all data has been transferred for the command and ending status posted.

The typical time from the receipt of an overlap command to the negation of BSY for a release is reported in Word 72 of the IDENTIFY DEVICE response.

Once the Release process has completed, the host may select the other device if it desires.

7.*.1.5 Proxy interrupt

The Proxy interrupt mechanism allows an unselected device to interrupt the host. The feature is enabled via the 5Fh SET FEATURES command and shall be enabled for overlapped operation in both devices.

When a device has an overlapped command outstanding, is not selected, but would like to interrupt the host to continue the processing of the overlapped command, the device shall assert the PDIAG signal.

When a device has the Proxy interrupt feature enabled via the 5Fh SET FEATURES command and the device is selected, the device shall monitor the PDIAG signal. If the PDIAG signal is asserted by the other device, the selected device shall assert the INTRQ signal on behalf of the non-selected device. If the selected device is in the process executing a command, BSY or DRQ set, the selected device shall postpone the assertion of INTRQ until BSY and DRQ have been cleared.

When the Device/Head register is written to select the device with the interrupt pending, the previously selected device shall cease asserting INTRQ within ns. The newly selected device shall set SERVICE, assert INTRQ and negate PDIAG no sooner than ns after the receipt of the SERVICE command but no later than ns. It is possible that the host will see INTRQ negate then reassert. See figure xx.

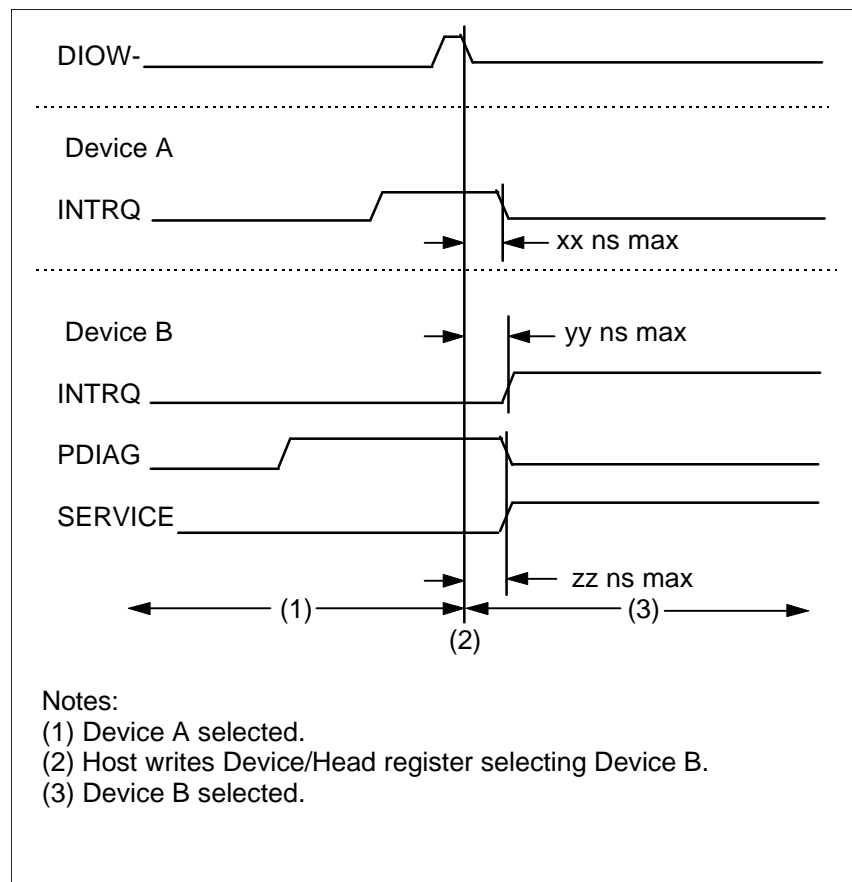

Figure xx - Selection of device with pending interrupt

When a selected device has a pending interrupt and INTRQ asserted, if the other device is selected by writing to the Device/Head register, the device shall negate INTRQ within xxns and assert PDIAG- within yyns. If the newly selected device has an interrupt pending and was asserting PDIAG-, the newly selected device shall negate PDIAG- within zzns and assert INTRQ within wwns. See figure yy.

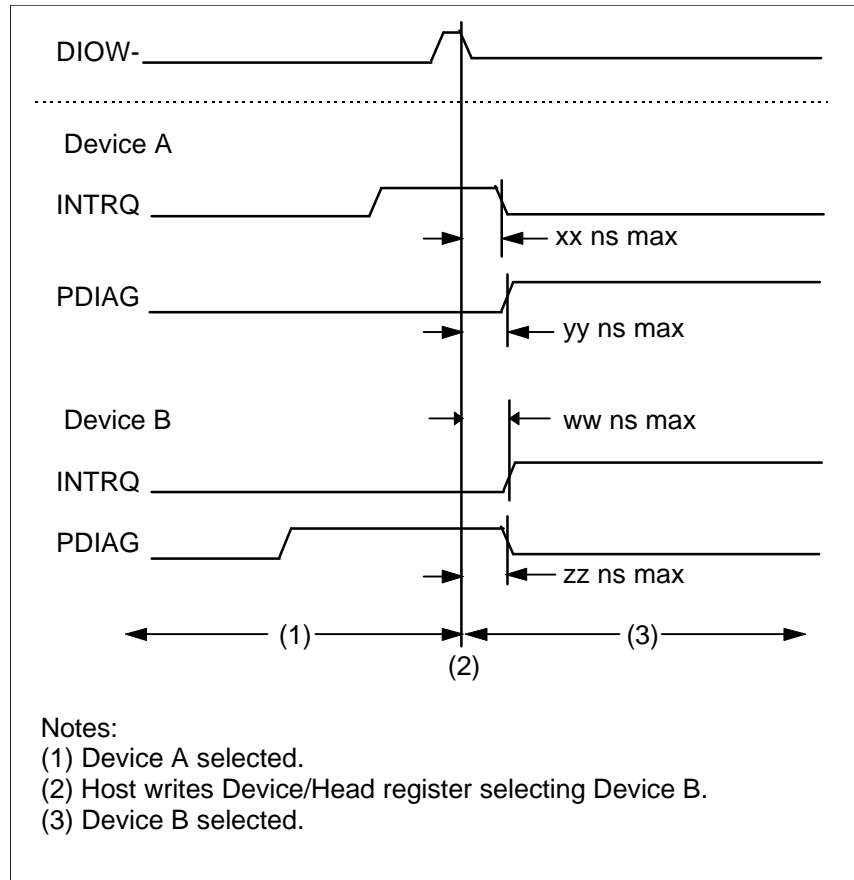

Figure yy Deselection of device with pending interrupt

If a selected device is busy executing a command, i.e., BSY or DRQ set, when the unselected device asserts PDIAG, the selected device shall not assert INTRQ until it is no longer busy. When the selected device completes its command, it may assert INTRQ on its own behalf to indicate the command completion. In this case, the selected device shall not assert INTRQ on behalf of the unselected device until qqns after INTRQ has been negated when the selected device interrupt pending is cleared. See figure zz.

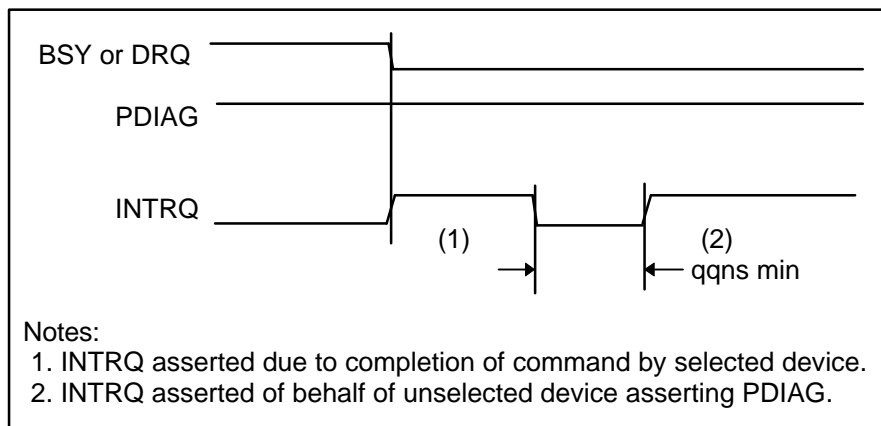

Figure zz - Proxy interrupt following selected device interrupt

7.*.1.6 SERVICE command

The SERVICE command is issued by the host to reselect a device that has an overlapped command outstanding and has released. The SERVICE command shall only be issued when the device has an overlapped command outstanding and has released. When a device that has released overlap command outstanding is ready to transfer data, the device sets the SERVICE bit. If selected, the device asserts INTRQ. If not selected, the device asserts PDIAG-.

Upon receipt of the SERVICE command, the device shall assert BSY, set the command tag and interrupt reason in the Sector Count register, clear SERVICE, set DRQ and DMARQ, then negate BSY. If the 5Eh SET FEATURES command is enabled, the device shall assert INTRQ after BSY has been negated. This allows the host to check the status associated with the overlapped command and continue the execution of the command.

7.*.2 Command queuing

Command queuing allows the host to issue multiple overlapped commands to the device. That is, additional overlapped commands may be issued to the device before previous overlapped commands are completed. To command queue, the device must have Proxy interrupts enabled via the SET FEATURES command. Only overlapped commands may be queued. If an overlapped command is outstanding when a non-overlapped command is received both commands and the queue will be aborted. The ending status shall be ABORT command and the results are indeterminant.

The maximum queue depth supported by a device shall be indicated in word 73 of the IDENTIFY DEVICE response.

A queued command shall have a tag provided by the host in the Sector Count register to uniquely identify the command. When the device restores register parameters during the execution of the SERVICE command, this tag shall be restored so that the host can identify the command for which status is being presented. If a queued command is issued with a tag value that is identical to the tag value for a command already in the queue, the entire queue shall be aborted including the new command. The ending status shall be ABORT command and the results are indeterminant. If an error causes the queue to be aborted, the QA bit shall be set in the register.

3.1 Definitions and abbreviations~~(add)~~

Command overlap - Command overlap is an optional feature that allows a host to issue commands or service outstanding commands with one device while a command is outstanding to the second device.

Command queuing - Command queuing is an optional feature that allows a host to have multiple commands outstanding to a given device.

Proxy interrupt - The Proxy Interrupt mechanism that allows an unselected device to signal the host that it wishes to continue execution of an outstanding overlapped command.

Release - A mechanism that allows the host to select the second device when the first device has an overlapped command outstanding.

5.2.10 INTRQ (Device interrupt)~~(add)~~

When both devices attached to the interface are capable of overlapped operation and enabled for Proxy interrupts, the PDIAG- signal is used by an unselected device to request the selected device to assert INTRQ on its behalf.

When a device has an overlapped command outstanding, is not selected, but would like to interrupt the host to continue the processing of the overlapped command, the device shall assert the PDIAG- signal.

When a device has the Proxy interrupt feature enabled via the 5Fh SET FEATURES command and the device is selected, the device shall monitor the PDIAG- signal. If the PDIAG- signal is asserted by the other device, the selected device shall assert the INTRQ signal on behalf of the non-selected device. If the selected device is in the process of a data transfer or other uninterruptable process, the selected device may postpone the assertion of INTRQ until the uninterruptable process has completed.

When the host writes the Device/Head register to select the other device, the previously selected device shall cease asserting INTRQ. The newly selected device shall assert INTRQ and negate PDIAG-. See xx.

5.2.13 PDIAG- (Passed diagnostics)(add)

When both devices attached to the interface are capable of overlapped operation and enabled for Proxy interrupts, the PDIAG- signal is used by an unselected device to request the selected device to assert INTRQ on its behalf.

When a device has an overlapped command outstanding, is not selected, but would like to interrupt the host to continue the processing of the overlapped command, the device shall assert the PDIAG- signal. PGIAG- shall not be negated until the device is selected.

When a device has the Proxy interrupt feature enabled via the 5Fh SET FEATURES command and the device is selected, the device shall monitor the PDIAG- signal. If the PDIAG- signal is asserted by the other device, the selected device shall assert the INTRQ signal on behalf of the non-selected device. If the selected device is in the process of a data transfer or other uninterruptable process, the selected device may postpone the assertion of INTRQ until the uninterruptable process has completed.

When the SERVICE command is issued, the previously selected device shall cease asserting INTRQ. The newly selected device shall assert INTRQ and negate PDIAG-. See xx.

6.2.9 Error register(add)

7	6	5	4	3	2	1	0
QA	UNC	MC	IDNF	MCR	ABRT	TK0NF	AMNF

Bit 7 - Queue aborted - for devices supporting command queuing, the assertion of QA indicates that an error has occurred that caused the queue to be aborted.

8.7 IDENTIFY DEVICE(add)

Table 14 - Identify Device Information (add)

Word	F/V	
73		Capabilities
	F	15 Interleaved DMA supported
	F	14 Command queuing supported
	F	13 Overlap operation supported
	F	4-0 Maximum queue depth the device supports
71	F	Typical time for Release after overlap command receipt in μ sec
72	F	Typical time for Release after SERVICE command receipt in μ sec

8.7.* Interleaved DMA support

Bit 15 of word 73 is used to indicated that the device supports interleaved DMA data transfer for overlapped DMA commands.

8.7.* Command Queuing supported

Bit 14 of word 73 is used to indicated that the device supports command queuing for overlapped commands.

8.7.* Command overlap supported

Bit 13 of word 73 is used to indicated that the device supports command overlap operation.

8.7.* Maximum queue depth supported

Bits 4 through 0 of word 73 indicate the maximum queue depth supported by the device. If bit 14 of word 73 is zero indicating that the device does not support command queuing, the value in this field shall be 00h.

8.7.* Time for release after overlap command receipt

If bit 13 in word 73 is set indicating the device supports command overlap, the value in word 71 shall be the typical time for release after an overlap command receipt in μ sec. If bit 13 in word 73 is cleared indicating the device does not support command overlap, the value in word 71 shall be 00h.

8.7.* Time for release after SERVICE command receipt

If bit 13 in word 73 is set indicating the device supports command overlap, the value in word 72 shall be the typical time for release after an overlap command receipt in μ sec. If bit 13 in word 73 is cleared indicating the device does not support command overlap, the value in word 72 shall be 00h.

8.* READ DMA OVERLAP

OPCODE - C7h

TYPE - Optional

PROTOCOL - DMA data in overlap

INPUTS - The Cylinder Low, Cylinder High, Device/Head and Sector Number registers specify the starting sector address to be read. The Features register specifies the number of sectors to be transferred. The Sector Count register contains the tag for this command if the device supports command queuing.

Register	7	6	5	4	3	2	1	0
Features	Sector Count							
Sector Count	Tag							
Sector Number	Sector number or LBA							
Cylinder Low	Cylinder low or LBA							
Cylinder High	Cylinder high or LBA							
Device/Head	1	LBA	1	D	Head number or LBA			
Command	C7h							

NORMAL OUTPUTS -

If the device has the requested data ready to transfer when the command is received, the device may transfer the data without releasing the bus. The register contents shall be set as shown below to execute the transfer.

Register	7	6	5	4	3	2	1	0	
Error									
Sector Count	Tag						REL	IO	C/D-
Sector Number									
Cylinder Low									
Cylinder High									
Device/Head	1		1	D					
Status	BSY	DRDY	DMA RDY	SERV	DRQ	COR R	IDX	ERR	

Sector Count register -

Bits 7-3 - Tag - If the device supports command queuing, this field shall contain the tag of the command being released. If the device does not support command queuing, this field shall be zeros.

Bit 2 - REL - This bit shall be cleared to zero.

Bit 1 - IO - This bit shall be set to one indicating that the data transfer is from device to host.

Bit 0 - C/D- - This bit shall be cleared to zero indicating that data is to be transferred.

Status register -

Bit 7 - BSY - This bit shall be cleared to zero.

Bit 6 - DRDY - As described in .

Bit 5 - DMARDY - This bit shall be set to one.

Bit 4 - SERV - This bit shall be cleared to zero.

Bit 3 - DRQ - This bit shall beset to one.

Bit 2 - CORR - As described in .

Bit 1 - IDX - As described in .
 Bit 0 - ERR - This bit shall be cleared to zero.

If the device releases during the execution of this command, the register content upon release shall be as shown below.

Register	7	6	5	4	3	2	1	0
Error								
Sector Count	Tag					REL		
Sector Number								
Cylinder Low								
Cylinder High								
Device/Head	1		1	D				
Status	BSY	DRDY	DMA RDY	SERV	DRQ	COR R	IDX	ERR

Sector Count register -

Bits 7-3 - Tag - If the device supports command queuing, this field shall contain the tag of the command being released. If the device does not support command queuing, this field shall be zeros.

Bit 2 - REL - This bit shall be set indicating that the device has released an overlap command.
 Bits 1-0 This field shall be zeros.

Status register -

Bit 7 - BSY - This bit shall be cleared to zero.

Bit 6 - DRDY - As described in .

Bit 5 - DMARDY - This bit shall be cleared to zero.

Bit 4 - SERV - This bit shall be cleared to zero when the device releases. This bit shall be set to one when the device is ready to transfer data.

Bit 3 - DRQ - This bit shall be cleared to zero.

Bit 2 - CORR - This bit shall be cleared to zero.

Bit 1 - IDX - As described in .

Bit 0 - ERR - This bit shall be cleared to zero.

When the transfer of all requested data has occurred without error, the register content shall be as shown below.

Register	7	6	5	4	3	2	1	0
Error	00h							
Sector Count	Tag					REL		
Sector Number								
Cylinder Low								
Cylinder High								
Device/Head	1		1	D				
Status	BSY	DRDY	DMA RDY	SERV	DRQ	COR R	IDX	ERR

Sector Count register -

Bits 7-3 - Tag - If the device supports command queuing, this field shall contain the tag of the completed command. If the device does not support command queuing, this field shall be zeros.

Bit 2 - REL - This bit shall be cleared to zero.

Bits 1-0 This field shall be zeros.

Status register -

Bit 7 - BSY - This bit shall be cleared to zero.

Bit 6 - DRDY - As described in .
 Bit 5 - DMARDY - This bit shall be cleared to zero.
 Bit 4 - SERV - This bit shall be cleared to zero.
 Bit 3 - DRQ - This bit shall be cleared to zero.
 Bit 2 - CORR - As described in .
 Bit 1 - IDX - As described in .
 Bit 0 - ERR - This bit shall be cleared to zero.

ERROR OUTPUTS - The Sector Count register contains the tag for this command if the device supports command queuing. Aborted command if the command is not supported or if the device has not had Proxy interrupt enabled. Aborted command if the device supports command queuing and the tag is invalid. An unrecoverable error encountered during the execution of this command results in the termination of the command and the Command Block registers contain the sector where the first unrecoverable error occurred. If a queue existed, the unrecoverable error shall cause the queue to abort and the QA bit to be set. The device may remain BSY for some time when responding to these errors.

Status register				Error register					
DRDY	DF	CORR	ERR	QA	BBK	UNC	IDNF	ARBT	AMNF
V	V		V	V	V		V	V	V

PREREQUISITES - The host shall initialize the DMA channel.

DESCRIPTION - This command executes in a similar manner to a READ DMA command. If the release interrupt has been enabled via a SET FEATURES command, the device shall release the bus when the command and its parameters have been "saved". If the release interrupt has been disabled via the SET FEATURES command, the device may release the bus or it may execute the data transfer without release if the data is ready to transfer.

If a release is executed, the host shall reselect the device using the SERVICE command.

See for the protocol utilized for overlapped commands.

8.* SERVICE

OPCODE - A2h

TYPE - Optional

PROTOCOL - Non-data command

INPUTS -

Register	7	6	5	4	3	2	1	0
Features								
Sector Count								
Sector Number								
Cylinder Low								
Cylinder High								
Device/Head	1		1	D				
Command	A2h							

NORMAL OUTPUTS -

Register	7	6	5	4	3	2	1	0
Error								
Sector Count	Tag					REL	IO	C/D-
Sector Number								
Cylinder Low								
Cylinder High								
Device/Head	1		1	D				
Status	BSY	DRDY	DMA RDY	SERV	DRQ	COR R	IDX	ERR

Sector Count register -

Bits 7-3 - Tag - If the device supports command queuing, this field shall contain the tag of the command being released. If the device does not support command queuing, this field shall be zeros.

Bit 2 - REL - This bit shall be set to one.

Bit 1 - IO - This bit shall be cleared to zero indicating that the data transfer is from host to device if the command being serviced is a write command. This bit shall be set to one indicating that the data transfer is from device to host if the command being serviced is a read command.

Bit 0 - C/D- - This bit shall be cleared to zero indicating that data is to be transferred.

Status register -

Bit 7 - BSY - This bit shall be cleared to zero.

Bit 6 - DRDY - As described in .

Bit 5 - DMARDY - This bit shall be set to one.

Bit 4 - SERV - This bit shall be cleared to zero.

Bit 3 - DRQ - This bit shall be set to one.

Bit 2 - CORR - As described in .

Bit 1 - IDX - As described in .

Bit 0 - ERR - This bit shall be cleared to zero.

ERROR OUTPUTS - Aborted command if the device does not support this command. Aborted error if no overlap command is currently in progress.

Status register				Error register					
DRDY	DF	CORR	ERR	QA	BBK	UNC	IDNF	ARBT	AMNF
V	V		V					V	

PREREQUISITES - This command shall be issued only when there is an overlap command in progress.

DESCRIPTION - Upon receipt of this command, the device shall set BSY, place the parameters for the command requiring service in the appropriate registers, and then clear BSY.

8.28 SET FEATURES(add)

Table 19 - Set Features register definitions (add)

Value	
5Dh	Enable interrupt for Release after the receipt of an overlap command.
5Eh	Enable interrupt after the processing of a SERVICE command.
5Fh	Enable Proxy interrupt
DDh	Disable interrupt for Release after the receipt of an overlap command.
DEh	Disable interrupt after the processing of a SERVICE command.
DFh	Disable Proxy interrupt

8.28.* Enable/disable release interrupt

Subcommand codes 5Dh and DDh allow a host to enable or disable the assertion of an interrupt when a device executing an overlap command releases the bus.

8.28.* Enable/disable SERVICE interrupt

Subcommand codes 5Eh and DEh allow a host to enable or disable the assertion of an interrupt when the device is ready to transfer at the completion of a SERVICE command.

8.28.* Enable/disable proxy interrupts

Subcommand codes 5Fh and DFh allow a host to enable the use of proxy interrupts to allow the use of overlap commands or to disable this feature.

8.* WRITE DMA OVERLAP

OPCODE - CCh

TYPE - Optional

PROTOCOL - DMA data out overlap

INPUTS - The Cylinder Low, Cylinder High, Device/Head and Sector Number registers specify the starting sector address to be written. The Features register specifies the number of sectors to be transferred. The Sector Count register contains the tag for this command if the device supports command queuing.

Register	7	6	5	4	3	2	1	0
Features	Sector Count							
Sector Count	Tag							
Sector Number	Sector number or LBA							
Cylinder Low	Cylinder low or LBA							
Cylinder High	Cylinder high or LBA							
Device/Head	1	LBA	1	D	Head number or LBA			
Command	CCh							

NORMAL OUTPUTS -

If the device is ready to accept the data when the command is received, the device may transfer the data without releasing the bus. The register contents shall be set as shown below to execute the transfer.

Register	7	6	5	4	3	2	1	0	
Error									
Sector Count	Tag						REL	IO	C/D-
Sector Number									
Cylinder Low									
Cylinder High									
Device/Head	1		1	D					
Status	BSY	DRDY	DMA RDY	SERV	DRQ	COR R	IDX	ERR	

Sector Count register -

Bits 7-3 - Tag - If the device supports command queuing, this field shall contain the tag of the command being released. If the device does not support command queuing, this field shall be zeros.

Bit 2 - REL - This bit shall be cleared to zero.

Bit 1 - IO - This bit shall be cleared to zero indicating that the data transfer is from host to device.

Bit 0 - C/D- - This bit shall be cleared to zero indicating that data is to be transferred.

Status register -

Bit 7 - BSY - This bit shall be cleared to zero.

Bit 6 - DRDY - As described in .

Bit 5 - DMARDY - This bit shall be set to one.

Bit 4 - SERV - This bit shall be cleared to zero.

Bit 3 - DRQ - This bit shall beset to one.

Bit 2 - CORR - As described in .
 Bit 1 - IDX - As described in .
 Bit 0 - ERR - This bit shall be cleared to zero.

If the device releases during the execution of this command, the register content upon release shall be as shown below.

Register	7	6	5	4	3	2	1	0
Error								
Sector Count	Tag					REL		
Sector Number								
Cylinder Low								
Cylinder High								
Device/Head	1		1	D				
Status	BSY	DRDY	DMA RDY	SERV	DRQ	COR R	IDX	ERR

Sector Count register -

Bits 7-3 - Tag - If the device supports command queuing, this field shall contain the tag of the command being released. If the device does not support command queuing, this field shall be zeros.

Bit 2 - REL - This bit shall be set indicating that the device has released an overlap command.

Bits 1-0 This field shall be zeros.

Status register -

Bit 7 - BSY - This bit shall be cleared to zero.

Bit 6 - DRDY - As described in .

Bit 5 - DMARDY - This bit shall be cleared to zero.

Bit 4 - SERV - This bit shall be cleared to zero when the device releases. This bit shall be set to one when the device is ready to transfer data.

Bit 3 - DRQ - This bit shall be cleared to zero.

Bit 2 - CORR - This bit shall be cleared to zero.

Bit 1 - IDX - As described in .

Bit 0 - ERR - This bit shall be cleared to zero.

When the transfer of all requested data has occurred without error, the register content shall be as shown below.

Register	7	6	5	4	3	2	1	0
Error	00h							
Sector Count	Tag					REL		
Sector Number								
Cylinder Low								
Cylinder High								
Device/Head	1		1	D				
Status	BSY	DRDY	DMA RDY	SERV	DRQ	COR R	IDX	ERR

Sector Count register -

Bits 7-3 - Tag - If the device supports command queuing, this field shall contain the tag of the completed command. If the device does not support command queuing, this field shall be zeros.

Bit 2 - REL - This bit shall be cleared to zero.

Bits 1-0 This field shall be zeros.

Status register -

Bit 7 - BSY - This bit shall be cleared to zero.
 Bit 6 - DRDY - As described in .
 Bit 5 - DMARDY - This bit shall be cleared to zero.
 Bit 4 - SERV - This bit shall be cleared to zero.
 Bit 3 - DRQ - This bit shall be cleared to zero.
 Bit 2 - CORR - As described in .
 Bit 1 - IDX - As described in .
 Bit 0 - ERR - This bit shall be cleared to zero.

ERROR OUTPUTS - The Sector Count register contains the tag for this command if the device supports command queuing. Aborted command if the command is not supported or if the device has not had Proxy interrupt enabled. Aborted command if the device supports command queuing and the tag is invalid. An unrecoverable error encountered during the execution of this command results in the termination of the command and the Command Block registers contain the sector where the first unrecoverable error occurred. If a queue existed, the unrecoverable error shall cause the queue to abort and the QA bit to be set. The device may remain BSY for some time when responding to these errors.

Status register				Error register					
DRDY	DF	CORR	ERR	QA	BBK	UNC	IDNF	ARBT	AMNF
V	V		V	V	V		V	V	V

PREREQUISITES - The host shall initialize the DMA channel.

DESCRIPTION - This command executes in a similar manner to a Write DMA command. If the release interrupt has been enabled via a SET FEATURES command, the device shall release the bus when the command and its parameters have been "saved". If the release interrupt has been disabled via the SET FEATURES command, the device may release the bus or it may execute the data transfer without release if the device can accept the data.

If a release is executed, the host shall reselect the device using the SERVICE command.

See for the protocol utilized for overlapped commands.

9.* Overlap command protocol

This class includes:

- READ DMA OVERLAP
- SERVICE
- WRITE DMA OVERLAP

Figure aa is a state diagram for the protocol for command overlap and command queuing commands. Figure BB provides an example of commands overlapped to two devices. Figure cc provides an example of two commands queued to a single device.

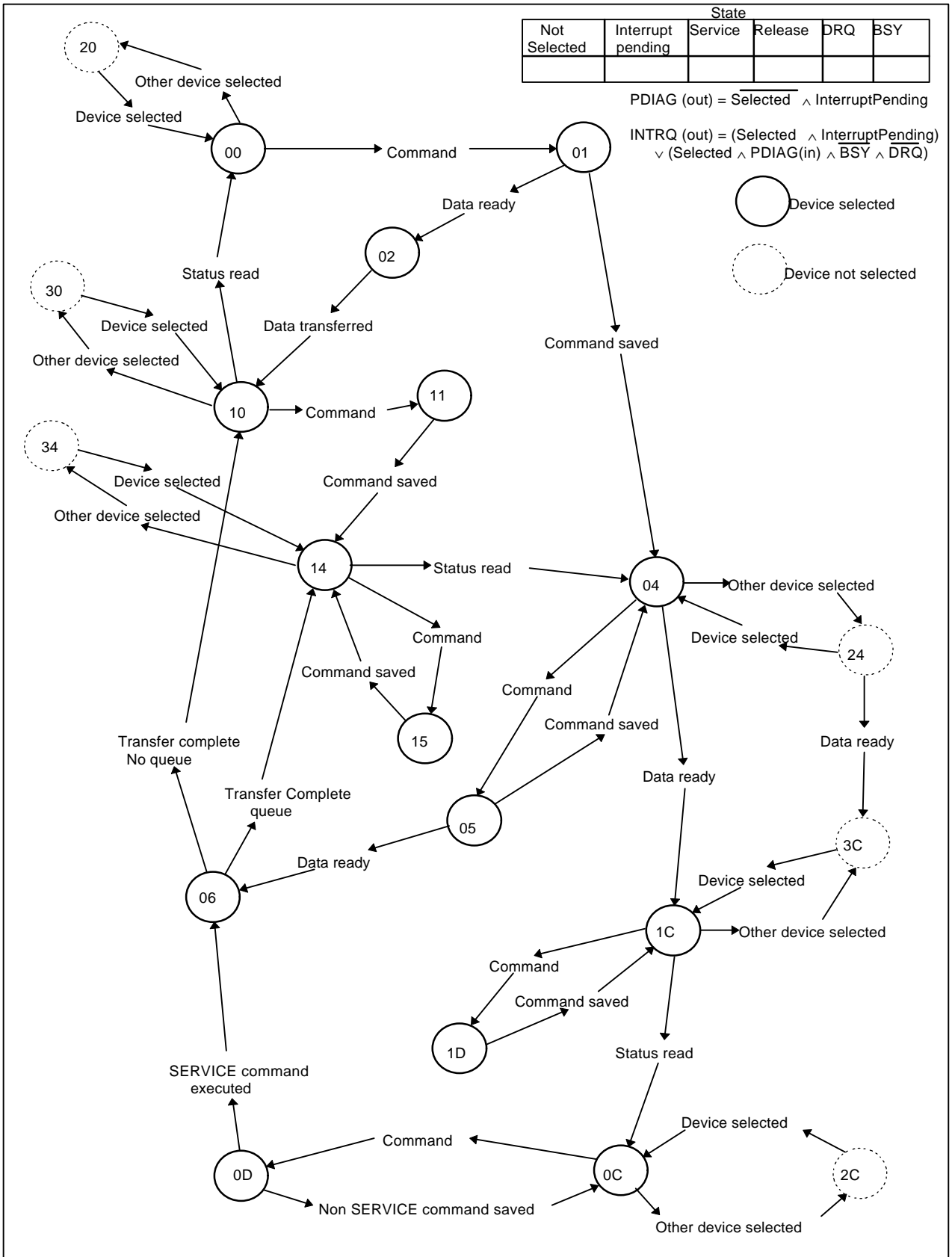

Figure aa - Command overlap and queuing state

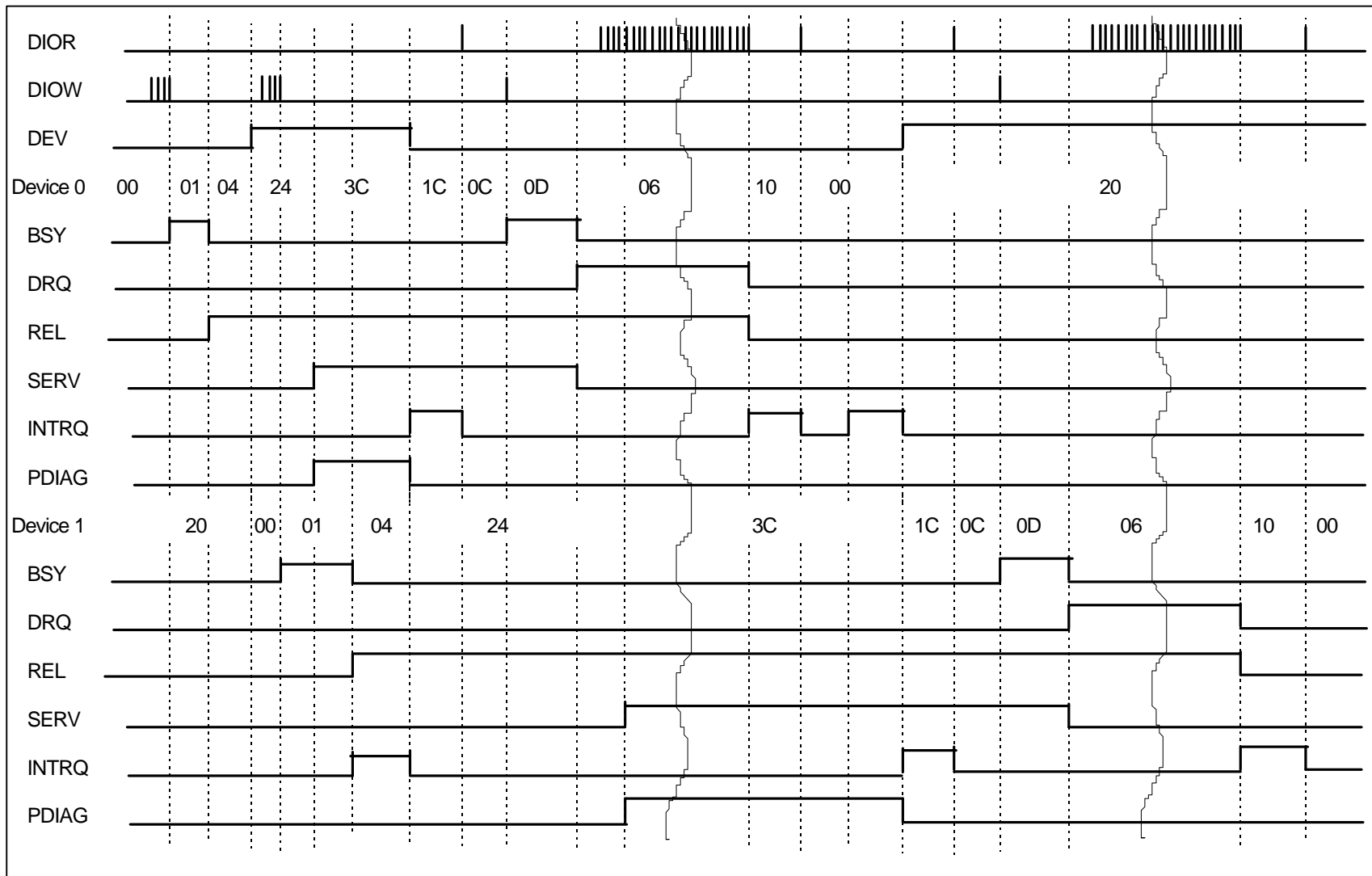

Figure bb - Two devices each with an overlapped command

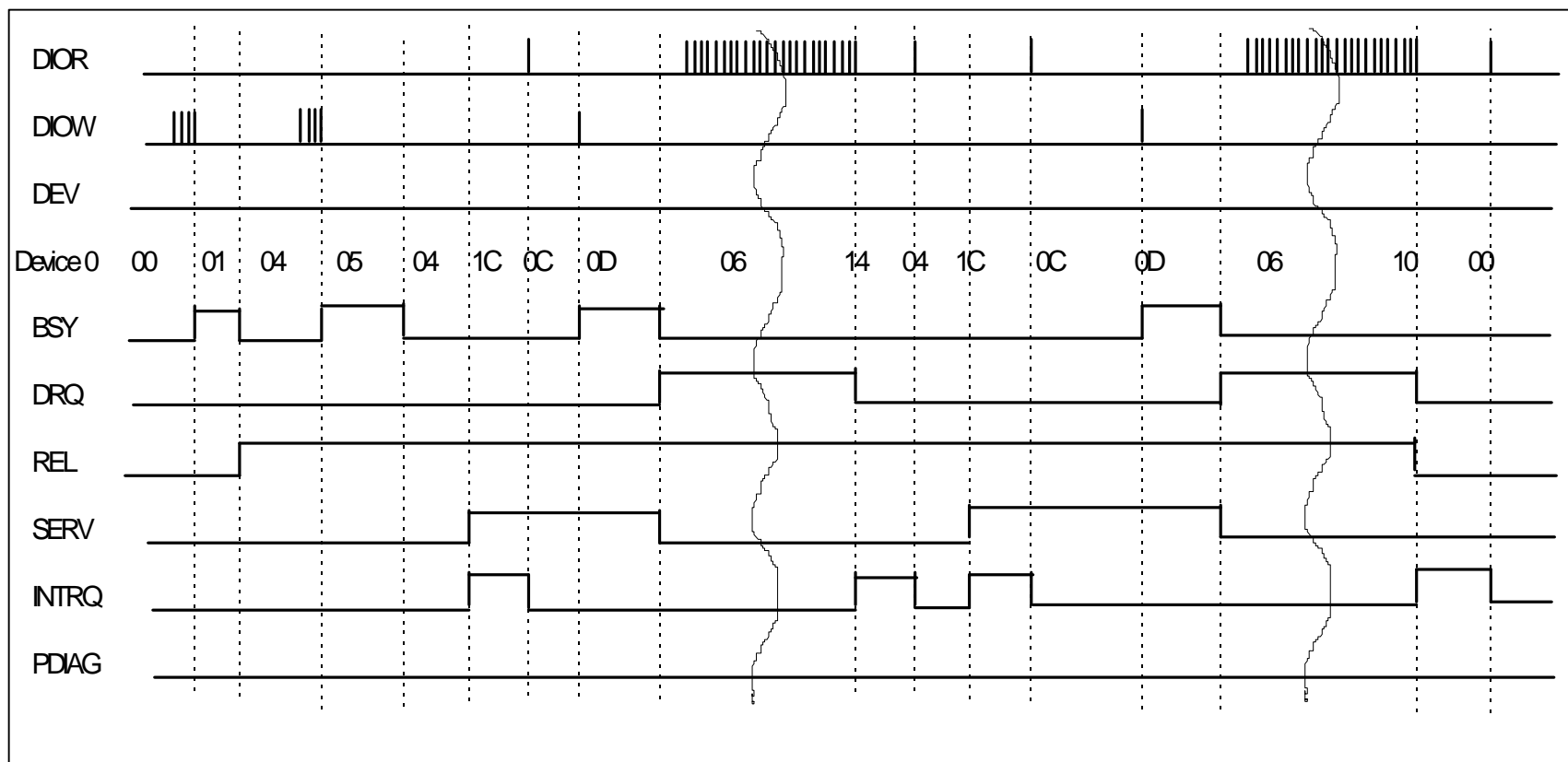

Figure cc - One device with two commands queued

Annex *

*****Editors Note: Should we create a new annex that includes Devon's diagrams for host behavior in overlap operation? *****